



MobiCrane The original
Mobile. Ergonomic. Lifting.

MobiCrane - handling made ergonomic, productive, and focused on the future.

MobiCrane is the mobile crane for handling pallet goods, sacks, crates, boxes, customised products and parts up to 85 kg. A customised MobiCrane can easily be configured to meet the requirements of these handling tasks. The system offers an extensive range of modules that are perfectly suited for all your handling applications. There is a wide variety of flexible options available from fully modular and mobile to pre-set and stationary configurations. The modular construction offers everything necessary to create ergonomic and efficient work stations.

Now and in the future.



Place it - Use it - Move it

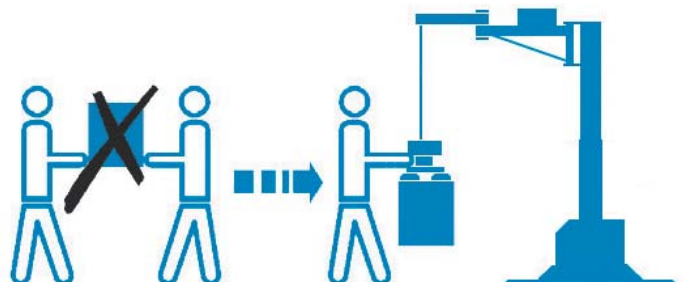

Grippers and attachments for diverse applications

We supply a variety of standard load-handling devices such as vacuum grippers or mechanical grippers. We also manufacture grippers that are individually customised to meet the requirements of your specific application.

Mechanical, magnetic and vacuum grippers



Sensor handle with stepless sliding control unit for optimal simplicity and ergonomics.



Suction cups with soft rubber strips are available in various sizes.

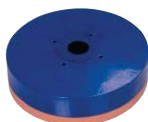

Round suction cups are available in various sizes for the handling of cans, drums, etc.



Mechanical manual control units with control button for operating the MobiCrane up/down.



H grippers with 4 adjustable suction cups are available in various designs.



I grippers with two adjustable suction cups are available in various designs.



Extendable telescope handle for ergonomic loading and stacking.



Rotating vacuum fitting with a pivoting radius of 360°.



Quick-change fittings for the quick and easy changing of various grippers.



90° bend/tilt fitting.



Rectangular suction cups are available in various sizes.

Standard and customized accessories



Small round suction cups for handling paint cans, etc. Also useful for handling applications in the explosion protection (EX) sector.



Customer-specific handling tools.



Piezo switch controller for variable speed control of the MobiCrane.



Vacuum Monitoring System -VMS for avoiding lift when the vacuum is too low.



Anti-Vacuum Shut-off Guard -AVSG for avoiding accidental/unintentional unloading.

Your flexibility comes from our modules

- The super flat floor plate ensures unobstructed accessibility around the crane. The mobile MobiCrane can also be moved to various sites of operation without the inconvenience of having to use a conventional forklift/pallet truck.
- The articulated arm is available in various lengths and offers the required range of movement. 360° around the crane.
- The crane mast comes standard with the ability to adjust the working/stacking height as well as the option to drive through doors and gates with the mobile MobiCrane.



Full flexibility even for attachments and grippers

- Our extensive standard product range offers numerous mechanical and vacuum grippers.
- Customized grippers will be tailor-made to fit your specifications using our know-how in handling.
- Without any considerable set-up times: Quick-change systems enable grippers to be changed within seconds. The widest variety of handling tasks can thereby be performed using a MobiCrane at the work station.

MobiCrane is the mobile crane system with the integrated electrical motor for lifting and rechargeable high-performance batteries. The modular system offers numerous additional options and alternative features. This modular product range can be configured all the way to the stationary machine, wall, or floor installation -**FixCrane**. Your crane can also be constructed as a mobile load bearing system -**MobiArm**- for chain hoists, vacuum tube lifters, balancers, etc. and thereby flexibly put to use for any handling task.

The concept MobiCrane

with the full modularity

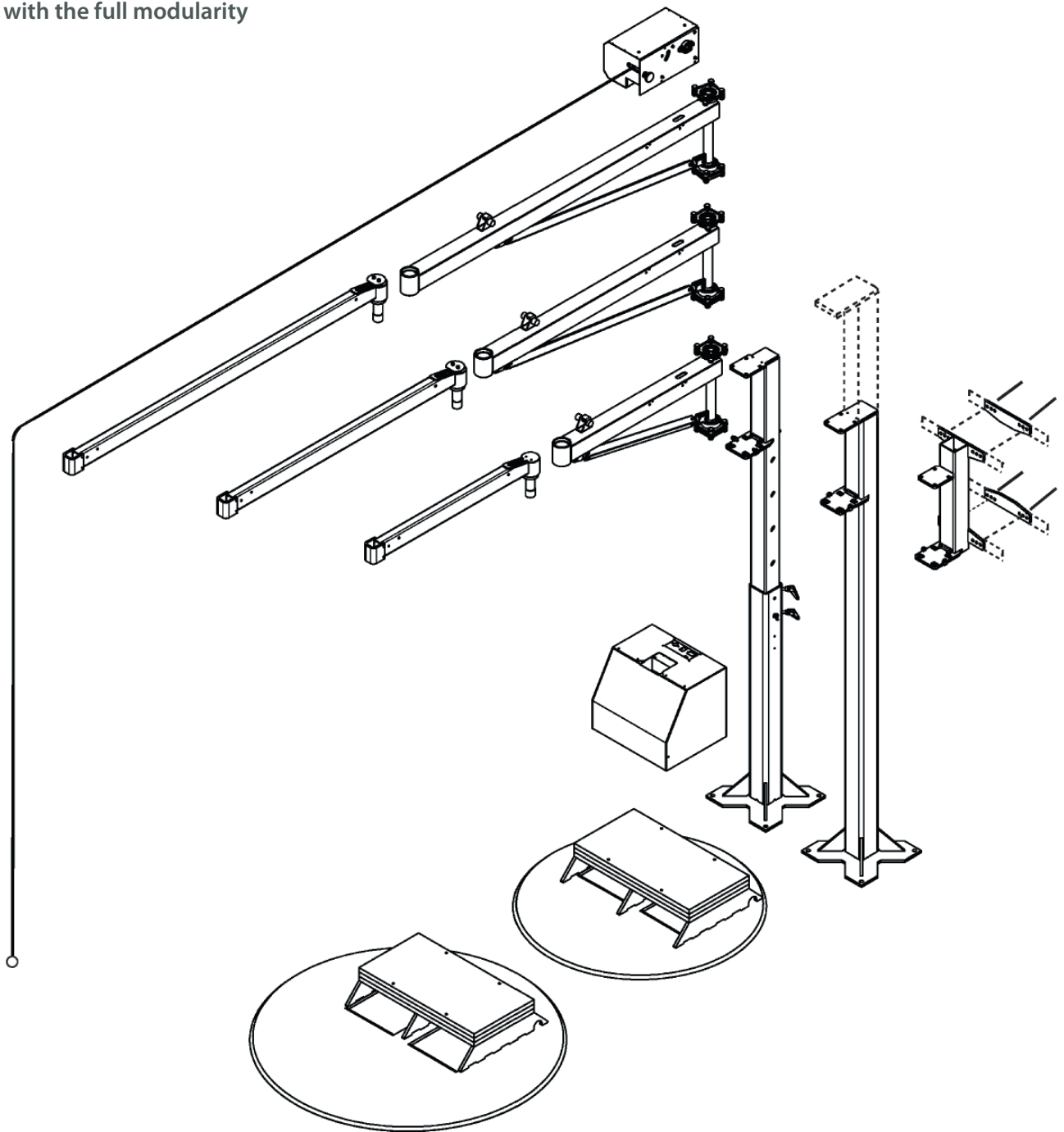

One MobiCrane

and all opportunities.

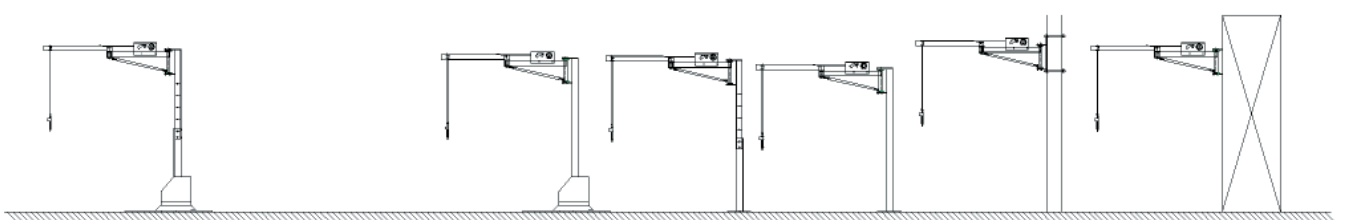

MobiCrane - Ergonomic technology in detail

Model-specific technical data:

Boom arm (mm)	2000	2500	3000	3500	4000
Load capacity (kg)	55/85	30/75	13/65	-/45	-/30
Tare weight (kg)	330/465	335/470	340/475	-/480	-/485

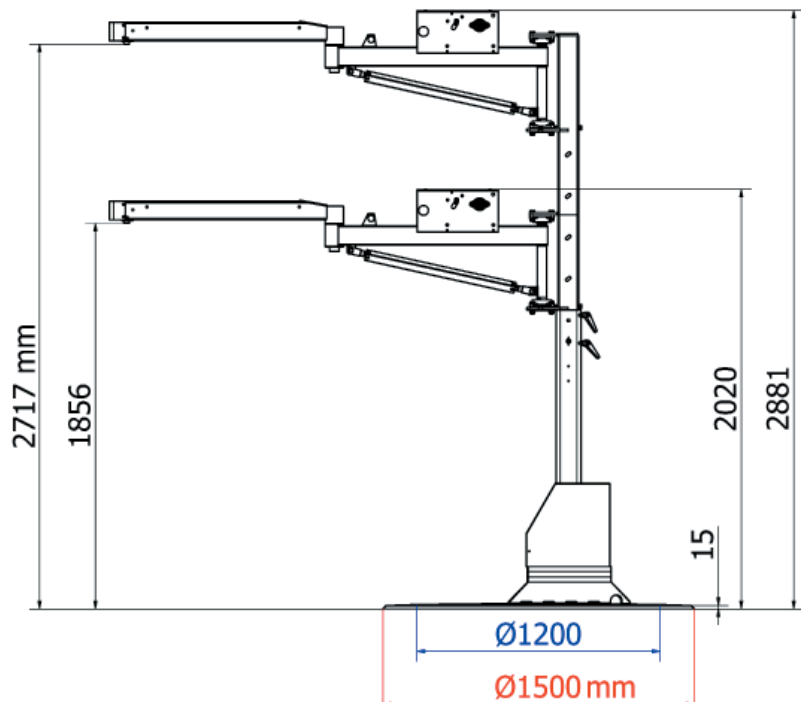
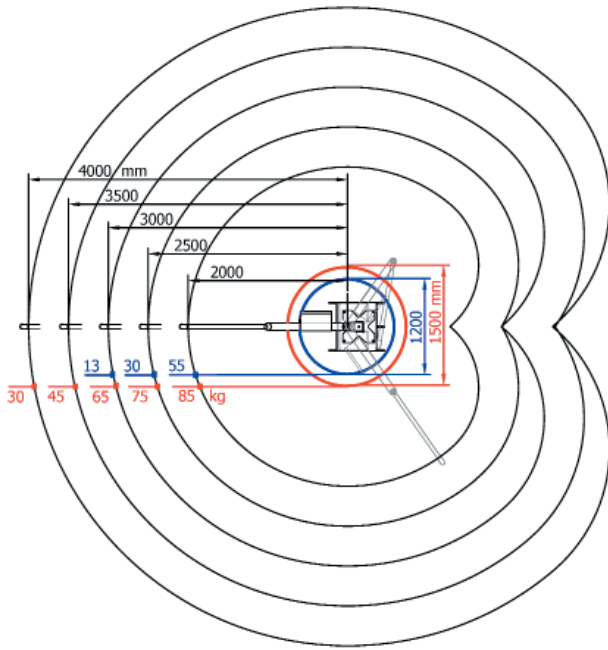

General technical data:

- > **Dimensions/configurations:** Please refer to the accompanying technical drawings for this data
- > **Maximum lifting height:** approximately 2300 mm depending on setting/height of lift mast and gripper
- > **Noise level:** 64 dB (A)/62 dB (B)
- > **Hoist rope:** Ø 6 mm with certified minimum load capacity of 1400 kg
Length 4800 - 6300 mm depending on the length of the boom arm being used
- > **Media supply:** Current
2 x 12 V/54 Ah rechargeable/maintenance-free batteries
or 200-240 V power supply
Pressurised air (required for vacuum grippers)
Volume flow 300, 450, or 600 l/min @ 6 bar
The pressurised air consumption varies depending on the required ejector.
The volume/pressure must be applied to the MobiCrane connection.

The technical data provided here can deviate depending on the model/configuration.

A large, abstract graphic composed of several overlapping, curved, light green shapes that resemble stylized leaves or petals, filling the middle section of the page.

We handle your material handling handily.

SMEYERS-TU NV/SA

Treft 61 / 3 B-1853 Strombeek-Bever

☎ 02-461 21 09 📠 02-461 21 44

www.pronomic-lift.be